

D Series



CARACTERISTICS

Fluid	Filtered and oilfree compressed air
Temperature range	STD diaphragm -40°C; +80°C Viton diaphragm -30°C; +200°C
Operating pressure	min. 0,5; max 7,5 bar
Body e coover	Die cast aluminium
Core tube	Stainless Steel
Plunger	Stainless Steel
Screws	Stainless Steel
Coil insulation	Class H
Connector	PG 9; IP65 DIN 43650 ISO 4400
Standard voltages	230 -110 - 24V / 50-60VHz 19 VA 24VDC 15W

DESCRIPTION	DP/DM20	DP/DM25
1 Coil+Connector	BH10...V/50-60Hz	BH10...V/50-60Hz
2 Screws+Washer	VTE6x20+VROS6	VTE6x20+VROS6
3 Pole assembly	GPC 10	GPC 10
4 Cover	TCOP 25	TCOP 25
5 Diaphragm	M20	M25
6 Body	TCOR20/25MMG	TCOR25MMG
7 Cover remote operated	TCOP25FM	TCOP25FM

DP Integral solenoid pilot version
DM Remote pilot version

DESCRIPTION	DP/DM40
1 Coil+Connector	BH10...V/50-60Hz
2 Screws+Washer	VTE6x20+VROS6
3 Pole assembly	GPC 10
4 Cover	TCOP 25
4 Remote cover	TCOP25FM
5 Diaphragm	M25
6 Screws + Washer	VTE8x20+VROS8
7 Main cover	TCOP 40N
8 Spring	TMOL40
9 Main diaphragm	M40
10Body	TCOR40MMG
11Cover remote operated	TCOP25FM

DP Integral solenoid pilot version
DM Remote pilot version

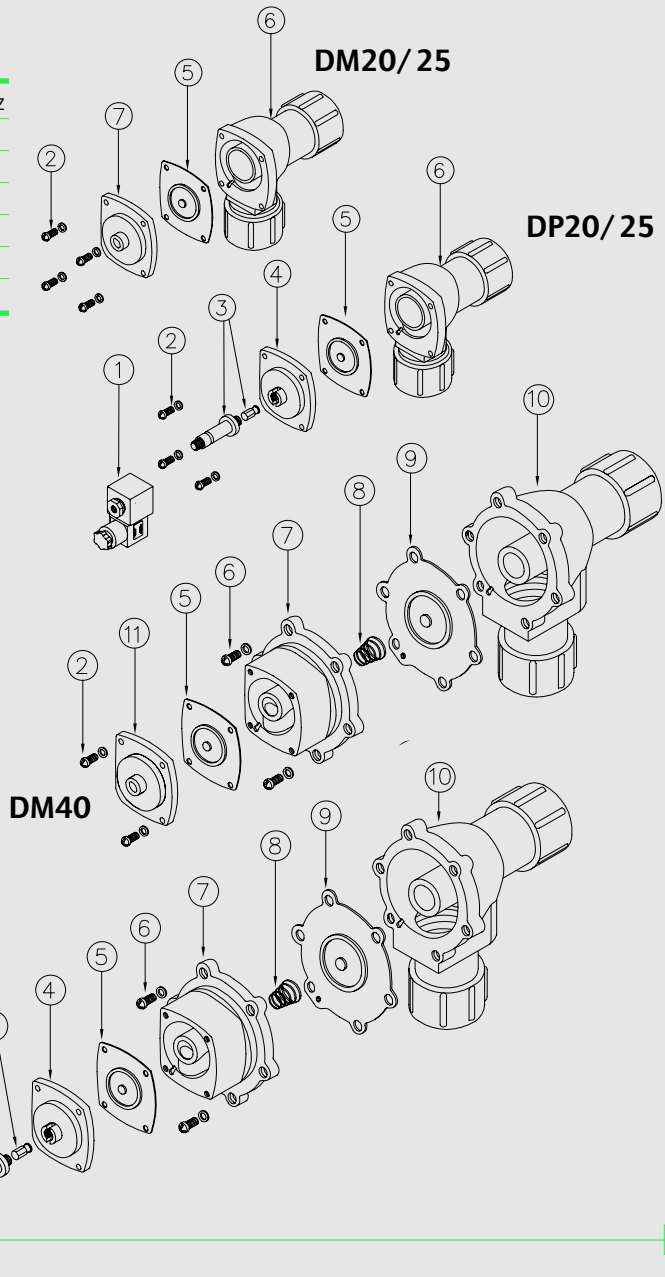

Dimensions mm **D** Series

DP20 - DP25

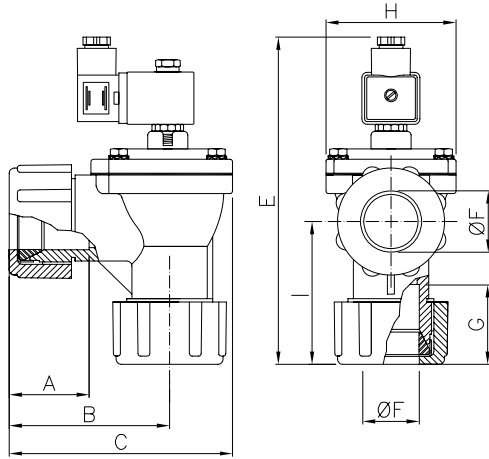

DM20 - DM25

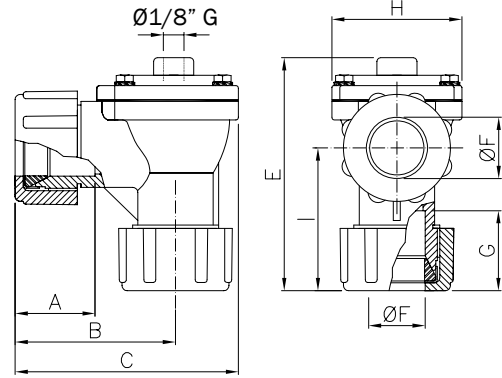

DP40

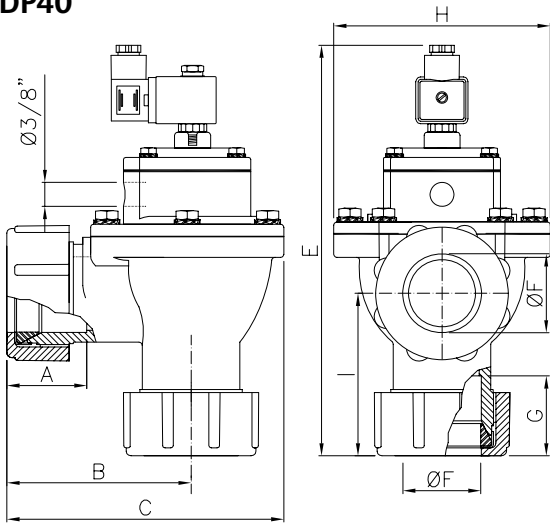

DM40

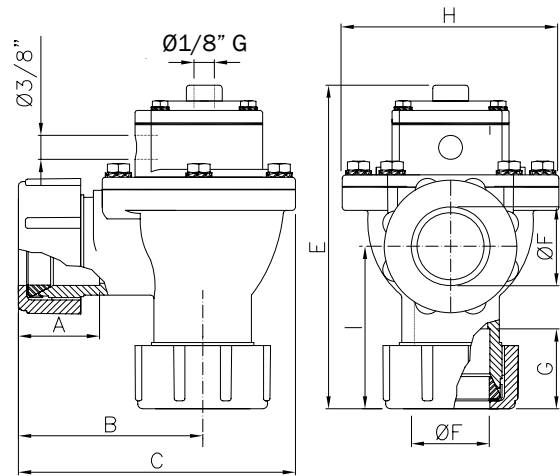

Model	Ø(nom)	A	B	C	E	F	G	H	I	L	Weight (Kg)	Model	E	Weight (Kg)
DP 20	3/4"	48	90	128	~189	28,5	48	74	80	30,5	1,1	DM 20	131	1
DP 25	1"	48	90	128	~189	35	48	74	80	30,5	1	DM 25	131	0,9
DP 40	1 1/2"	66	114	180	~264	50	66	140	101	39	2,4	DM 40	206	2,3