

**F Series**



**CHARACTERISTICS**

<b>Fluid</b>	Filtered and oilfree compressed air
<b>Temperature range</b>	STD diaphragm -40°C; +80°C Viton diaphragm -30°C; +200°C
<b>Operating pressure</b>	min. 0,5; max 7,5 bar
<b>Body e cover</b>	Die cast aluminium
<b>Core tube</b>	Stainless Steel
<b>Plunger</b>	Stainless Steel
<b>Screws</b>	Stainless Steel
<b>Coil insulation</b>	Class H
<b>Connector</b>	PG 9; IP65 DIN 43650 ISO 4400
<b>Standard voltage</b>	230 -110 - 24V / 50-60VHz 19 VA 24VDC 15W

DESCRIPTION	FP/ FM20	FP/ FM25
1 Coil+Connector	BH10...V/50-60Hz	BH10...V/50-60Hz
2 Screws+Washer	VTE6x20+VROS6	VTE6x20+VROS6
3 Pole assembly	GPC 10	GPC 10
4 Cover	TCOP 25	TCOP 25
5 Diaphragm	M25	M25
6 Body	TCOR20FFG	TCOR20FFG
7 Cover remote operated	TCOP25FM	TCOP25FM

FP Integral solenoid pilot version  
FM Remote pilot version

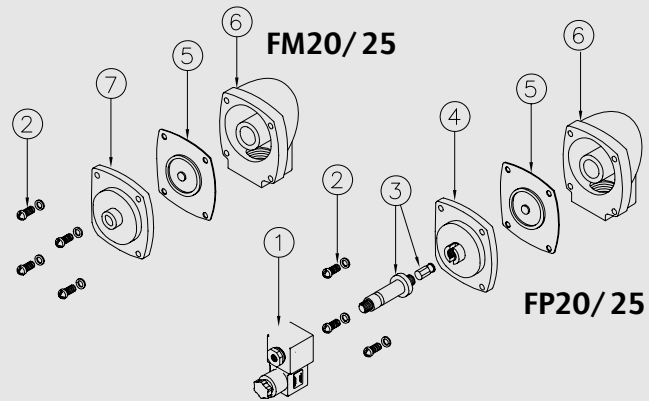

DESCRIPTION	FP/ FM40	FP/ FM55	FP/ FM65
1 Coil+Connector	BH10...V/50-60Hz	BH10...V/50-60Hz	BH10...V/50-60Hz
2 Screws+Washer	VTE6x20+VROS6	VTE6x20+VROS6	VTE6x20+VROS6
3 Pole assembly	GPC 10	GPC 10	GPC 10
4 Cover	TCOP 25	TCOP 25	TCOP 25
5 Diaphragm	M25	M25	M25
6 Screws + Washer	VTE8x20+VROS8	VTE10x25+VROS10	VTE10x25+VROS10
7 Main cover	TCOP 40	TCOP 65G	TCOP 65G
8 Spring	TMOL40	TMOL40	TMOL40
9 Main diaphragm	M40	M55	M75
10 Body	TCOR40FFG	TCOR55FFG	TCOR65FFG
11 Cover remote operated	TCOP25FM	TCOP25FM	TCOP25FM

FP Integral solenoid pilot version  
FM Remote pilot version

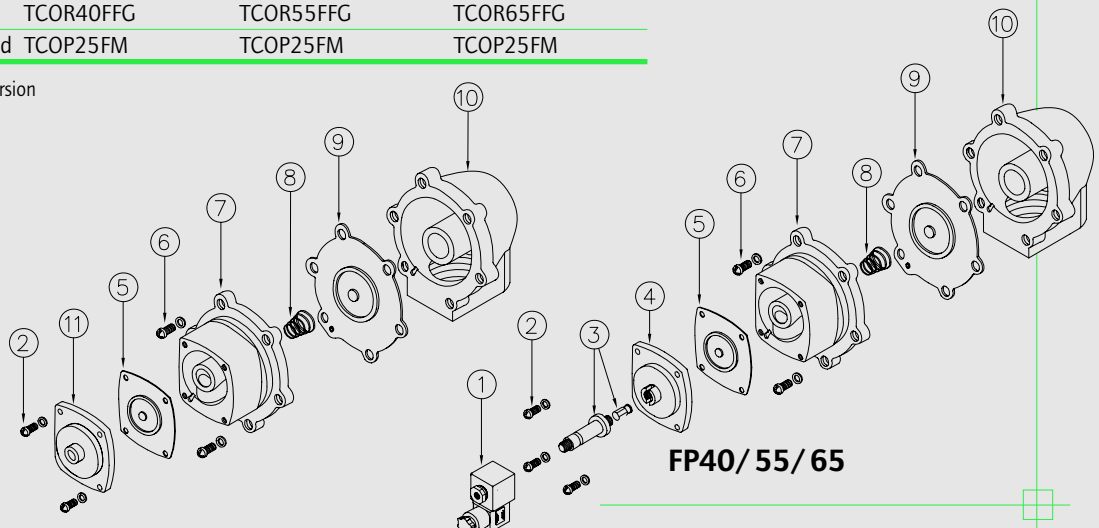

Dimension mm **F** Series

**FP20 - FP25**

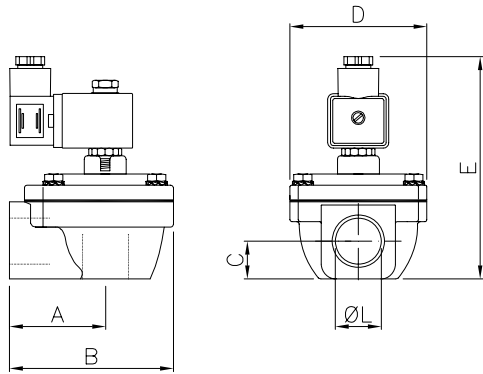

**FM20 - FM25**

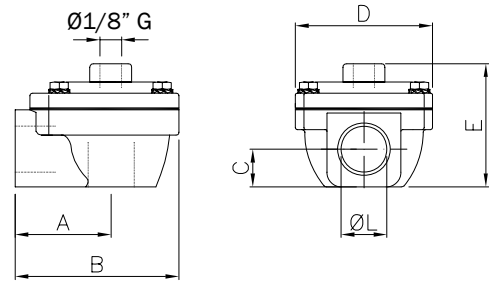

**FP40 - FP55 - FP65**

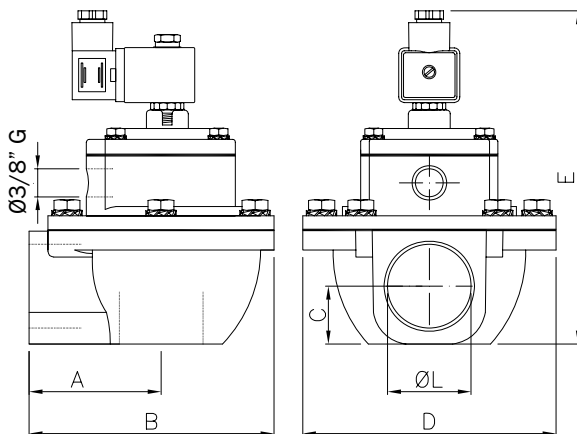

**FM40 - FM55 - FM65**

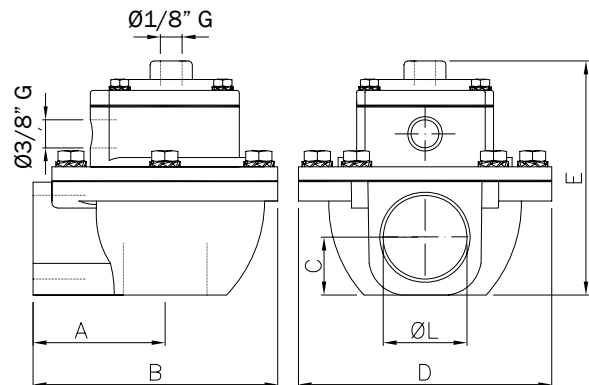

Model	Ø L (nom)	A	B	C	D	E	Weight (Kg)	Model	E	Weight (Kg)
<b>FP 20</b>	3/4"	52	90	20,5	74	~125	0,6	<b>FM 20</b>	67	0,4
<b>FP 25</b>	1"	52	90	20,5	74	~125	0,5	<b>FM 25</b>	67	0,4
<b>FP 40</b>	1 1/2"	71,3	135	31	140	~188	1,6	<b>FM 40</b>	130	1,4
<b>FP 55</b>	2"	114	203	40	194	~225	3,5	<b>FM 55</b>	167	3,4
<b>FP 65</b>	2 1/2"	114	203	48	194	~225	3,4	<b>FM 65</b>	167	3,2