

## Series ALUTANK with valve dn 1 1/2"

6"

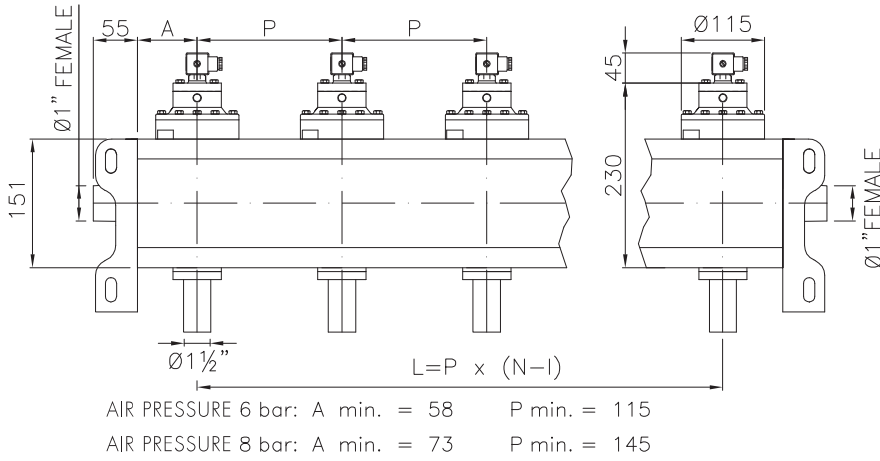

### TECHNICAL CARECTERISTICS

- Tank  
Extruded anodized aluminium
- Ends  
Diecast aluminium
- Blow tube  
Steel zinc plated
- O-Rings  
NBR
- Temperature range  
-10°C +80°C
- Operating pressure  
0,5 : 6 BAR - 0,5 : 8 BAR
- Low temperature  
-40°C +80°C  
with SST blow tube

### DESCRIZIONE

### VALVE SQP35/SQM35

1	Coil + Din connector	BH10...V/50-60Hz
2	Screws + Washer	VTE6x18+VROS6
3	Pole assembly	GPC 10
4	Cover	TCOP 10
5	Cover remote operated	TCOP 10FM
6	Spring	TMOL25GNEW
7	Diaphragm	M10
8	Screws + Washer	VTE6x20+VROS6
9	Cover	TCOP35N
10	Spring	TMOL40/45G
11	Main diaphragm	M35-S
12	Body	TCOR35FMGS

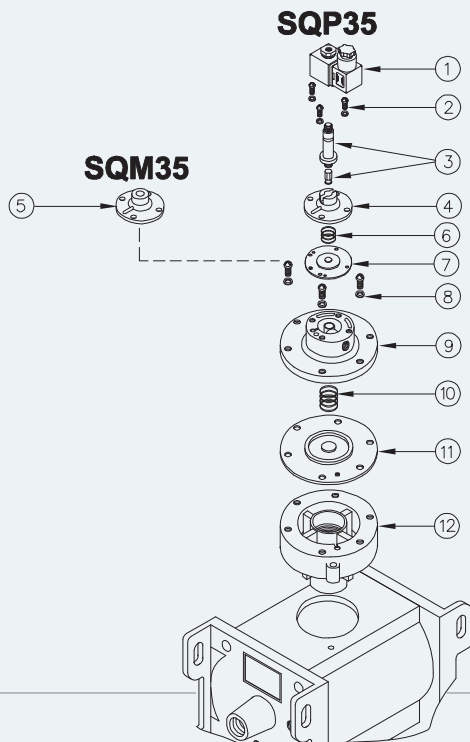

### MOUNTING HOLES

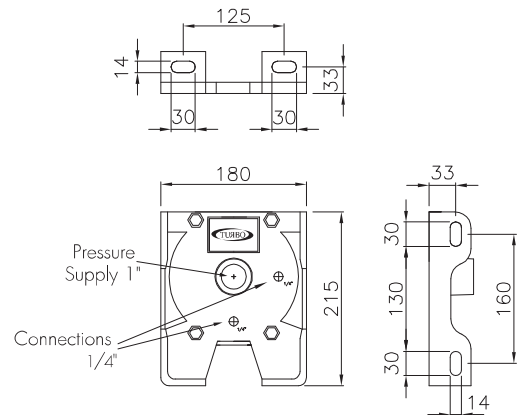

- SHORT PLAIN TUBE = G1
- LONG PLAIN TUBE = G2
- THREADED LONG TUBE = G3
- THREADED SHORT TUBE = G4

1 1/2"

